



Document: ISO/TC 176/SC 2/N **544R2**

Our ref

Secretariat of ISO/TC 176/SC 2

Date: 4 December 2003

ISO 9000 Introduction and Support Package: Guidance on the Concept and Use of the Process Approach for management systems

In conjunction with the publication of the International Standards ISO 9001:2000 and ISO 9004:2000, ISO/TC 176/SC 2 has published a number of guidance modules:

- N524 – Guidance on ISO 9001:2000 clause 1.2 'Application'
- N525 – Guidance on the Documentation requirements of ISO 9001:2000
- N526 – Guidance on the Terminology used in ISO 9001:2000 and ISO 9004:2000 ⁻¹⁾
- N544 – Guidance on the Concept and Use of the Process Approach for management systems
- N630 – Guidance on 'Outsourced Processes'

⁽¹⁾ This module was developed jointly with ISO/TC 176/SC1/WG2. ISO/TC 176/SC1 was responsible for the development of ISO 9000:2000 *Quality management systems - Fundamentals and vocabulary*

Together these are being made available as the ISO/TC 176/SC 2 'ISO 9000 Introduction and Support Package.

Feedback from users of the standards will be used to determine whether additional modules should be developed, or if these published modules should be revised.

The modules, and further information on the year 2000 ISO 9000 standards, may be downloaded from the following web sites:

www.iso.org
<http://www.bsi.org.uk/iso-tc176-sc2>

C Corrie
for BSI Secretariat
ISO/TC 176/SC 2

ISO 9000 Introduction and Support Package: Guidance on the Concept and Use of the Process Approach for management systems

1) Introduction

Key words: management system, process approach, system approach to management

Content

1. Introduction	2
2. What is a process?	3
3. Types of processes	3
4. Understanding the process approach	4
5. Implementing the process approach	6
5.1 Identification of processes of the organization (system approach to management)	6
5.2 Planning of the process	8
5.3 Implementation and measurement of the process	10
5.4 Analysis of the process	10
5.5. Corrective action and improvement of the process	10

1. Introduction

This guidance document provides an understanding of the concepts, intent and the application of the “process approach” to the ISO 9000 family of Quality Management System standards. The guidance may also be used to apply the process approach to any management system regardless of the type or the size of organization. This includes but is not limited to management systems for:

- Environment (ISO 14000 family),
- Occupational Health and Safety,
- Business Risk,
- Social Responsibilities.

This guide also aims to promote a consistent approach to the description of processes and use of process related terminology.

The purpose of the process approach is to enhance an organization’s effectiveness and efficiency in achieving its defined objectives.

Benefits of the process approach are:

- Integration and alignment of processes to enable achievement of planned results.
- Ability to focus effort on process effectiveness and efficiency.
- Provision of confidence to customers, and other interested parties, about the consistent performance of the organization.
- Transparency of operations within the organization.
- Lower costs and creates shorter cycle times, through the effective use of resources.
- Improved, consistent and predictable results.
- Provision of opportunities for focused and prioritized improvement initiatives.

**ISO 9000 Introduction and Support Package:
Guidance on the Concept and Use of the Process Approach for
management systems**

- Encouragement of the involvement of people and the clarification of their responsibilities.

ISO 9000 Introduction and Support Package: Guidance on the Concept and Use of the Process Approach for management systems

2. What is a process?

A “Process” can be defined as a “Set of interrelated or interacting activities, which transforms inputs into outputs”. These activities require allocation of resources such as people and materials. Figure 1 shows the generic process.

A major advantage of the process approach, when compared to other approaches, is in the management and control of the interactions between these processes and the interfaces between the functional hierarchy of the organization (as further explained in section 4).

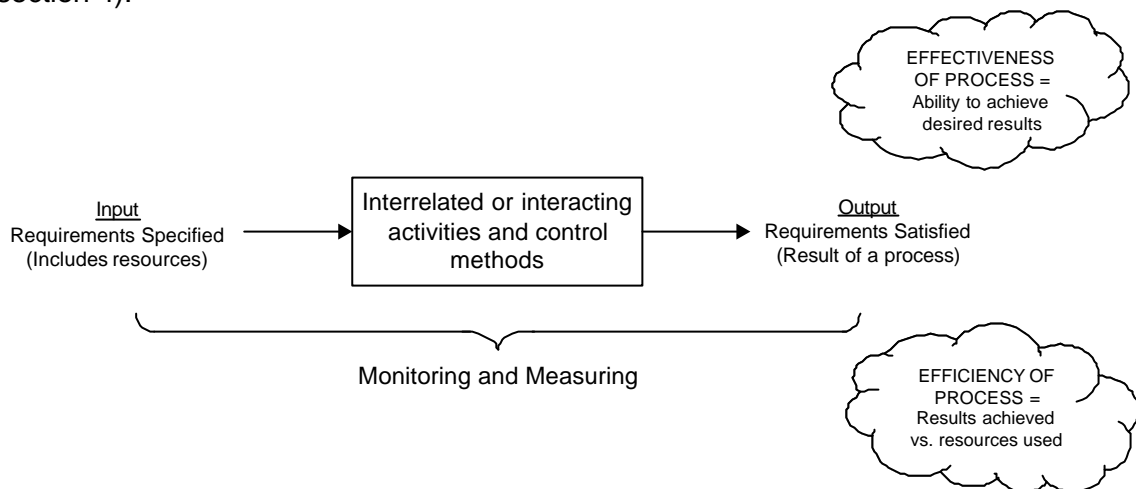

Figure 1. Generic process.

Inputs and intended outputs may be tangible (such as equipment, materials or components) or intangible (such as energy or information). Outputs can also be unintended; such as waste or pollution.

Each process has customers and other interested parties (who may be either internal or external to the organization) that are affected by the process and who define the required outputs according to their needs and expectations.

A system should be used to gather data, which can be analyzed to provide information about process performance and to determine the need for corrective action or improvement.

All processes should be aligned with the objectives of the organization and be designed to add value, relative to the scope and complexity of the organization.

Process effectiveness and efficiency can be assessed through internal or external review processes.

3. Types of processes

The following types of processes can be identified:

ISO 9000 Introduction and Support Package: Guidance on the Concept and Use of the Process Approach for management systems

- *Processes for management of an organization.* These include processes relating to strategic planning, establishing policies, setting objectives, providing communication, ensuring availability of resources needed and management reviews.
- *Processes for managing resources.* These include all those processes for the provision of the resources that are needed for the processes for managing an organization, for realization, and for measurement.
- *Realization processes.* These include all processes that provide the intended output of the organization.
- *Measurement, analysis and improvement processes.* These include those processes needed to measure and gather data for performance analysis and improvement of effectiveness and efficiency. They include measuring, monitoring and auditing processes, corrective and preventive actions and are an integral part of the management, resource management and realization processes.

4. Understanding the process approach

A process approach is a powerful way of organizing and managing how work activities create value for the customer and other interested parties.

Organizations are often structured into a hierarchy of functional units. Organizations are usually managed vertically, with responsibility for the intended outputs being divided among functional units. The end customer or other interested party is not always visible to all involved. Consequently, problems that occur at the interface boundaries are often given less priority than the short-term goals of the units. This leads to little or no improvement to the interested party, as actions are usually focused on the functions, rather than overall benefit to the organization.

The process approach introduces horizontal management, crossing the barriers between different functional units and unifying their focus to the main goals of the organization. It also improves management of process interfaces (see Figure 2).

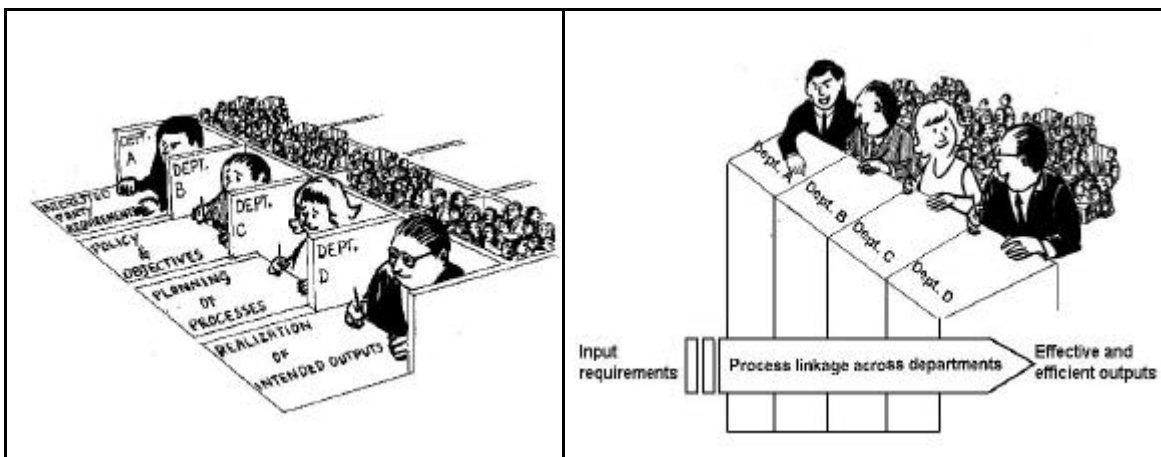

ISO 9000 Introduction and Support Package: Guidance on the Concept and Use of the Process Approach for management systems

Figure 2. Example of Process linkages across departments in an organization.

The performance of an organization can be improved through the use of the process approach. The processes are managed as a system, by creating and understanding a network of the processes and their interactions.

Note: The consistent operation of this network is often referred to as the "system approach" to management.

The outputs from one process may be inputs to other processes and interlinked into the overall network or system (for generic examples, see Figure 3 and Figure 4).

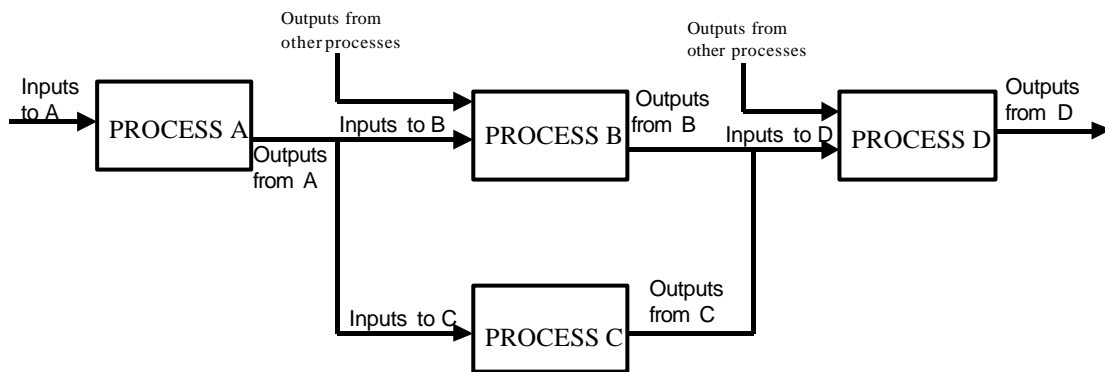
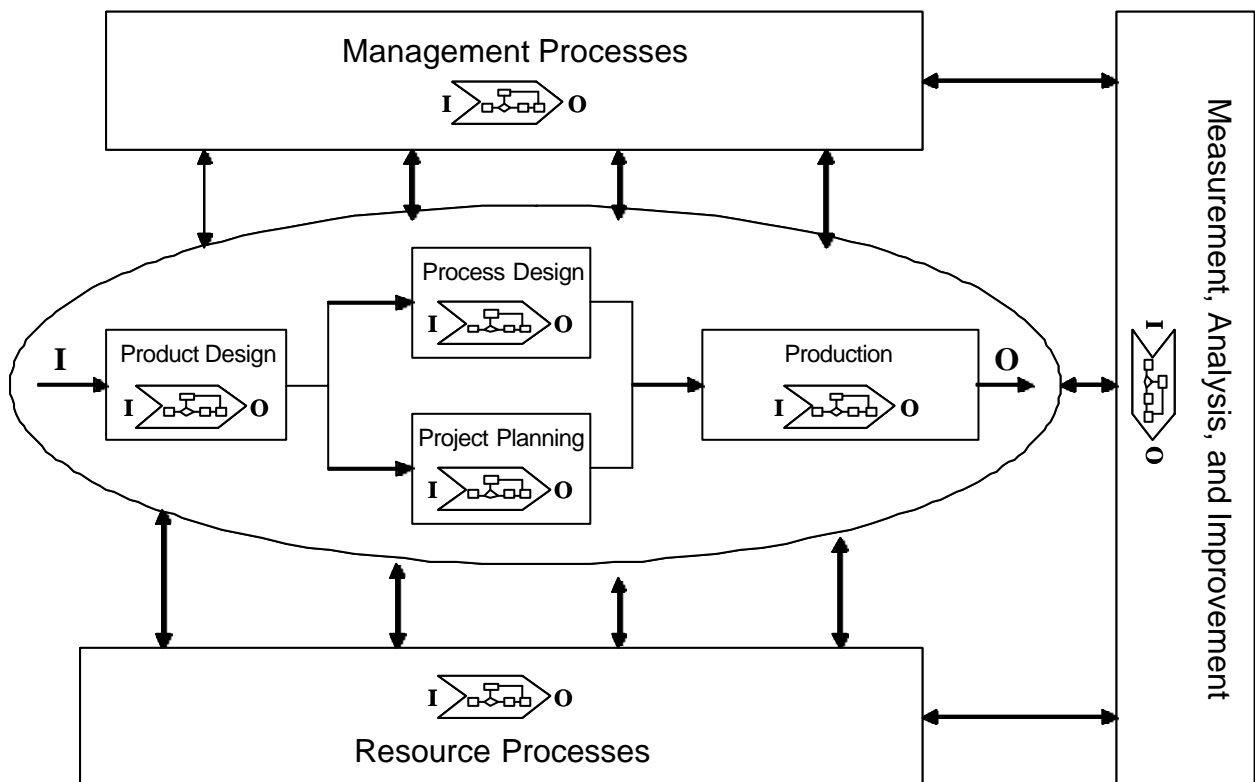

Figure 3. Example of a generic process sequence



**ISO 9000 Introduction and Support Package:
Guidance on the Concept and Use of the Process Approach for
management systems**

Figure 4. Example of a process sequence and its interactions.

**ISO 9000 Introduction and Support Package:
Guidance on the Concept and Use of the Process Approach for management systems**

5. Implementing the process approach

The following implementation methodology can be applied to any type of process. The step sequence is only one method and is not intended to be prescriptive. Some steps may be carried out simultaneously.

5.1 Identification of processes of the organization

Steps in the process approach	What to do?	Guidance
5.1.1 Define the purpose of the organization	The organization should identify its customers and other interested parties as well as their requirements, needs and expectations to define the organization's intended outputs.	Gather, analyze and determine customer and other interested parties requirements, and other needs and expectations. Communicate frequently with customers and other interested parties to ensure continual understanding of their requirements, needs and expectations. Determine the requirements for quality management, environmental management, occupational health and safety, management, business risk, social responsibilities and other management system disciplines that will be applied within the organization.
↓		
5.1.2 Define the policies and objectives of the organization	Based on analyses of the requirements, needs and expectations, establish the organization's policies and objectives	Top management should decide which markets the organization should address and develop relevant policies. Based on these policies, management should then establish objectives for the intended outputs (e.g. products, environmental performance, occupational health and safety performance)
↓		
5.1.3 Determine the processes in the organization	Identify all the processes that are needed to produce the intended outputs	Determine the processes needed for achieving the intended outputs. These processes include Management, Resources, Realization and Measurement and Improvement. Identify all process inputs and outputs, along with the suppliers, customers and other interested parties (who may be internal or external).
↓		
5.1.4 Determine the sequence of	Determine how the processes flow in sequence and interaction	Define and develop a description of the network of processes and their interaction. Consider the following:

**ISO 9000 Introduction and Support Package:
Guidance on the Concept and Use of the Process Approach for management systems**

the processes		<ul style="list-style-type: none"> • The customer of each process, • The inputs and outputs of each process, • Which processes are interacting, • Interfaces and what are their characteristics, • Timing and sequence of the interacting processes, • Effectiveness and efficiency of the sequence. <p>Note: As an example, processes that result in an output (such as product delivered to a customer) will interact with other processes (such as the management, measurement and monitoring, and resource provision processes).</p> <p>Methods and tools such as block diagrams, matrix and flowcharts can be used to support the development of process sequences and their interactions.</p>
5.1.5 Define process ownership	Assign responsibility and authority for each process.	<p>Management should define individual roles and responsibilities for ensuring the implementation, maintenance and improvement of each process and its interactions. Such an individual is usually referred to as the "process owner".</p> <p>To manage process interactions, it may be useful to establish a "process management team", that has an overview across all the processes, and which includes representatives from each of the interacting processes.</p>
5.1.6 Define process documentation	Determine those processes that are to be documented and how	<p>Processes exist within the organization and the initial approach should be limited to identifying and managing them in the most appropriate way. There is no "catalogue", or list of processes, that have to be documented.</p> <p>The main purpose of documentation is to enable the consistent and stable operation of the processes.</p> <p>The organization should determine which processes are to be documented, on the basis of:</p> <ul style="list-style-type: none"> • The size of the organization and its type of activities, • The complexity of its processes and their interactions, • The criticality of the processes, and

**ISO 9000 Introduction and Support Package:
Guidance on the Concept and Use of the Process Approach for management systems**

		<ul style="list-style-type: none"> The availability of competent personnel. <p>When it is necessary to document processes, a number of different methods can be used such as graphical representations, written instructions, checklists, flow charts, visual media, or electronic methods.</p> <p>Note: For more guidance see the ISO 9000 Introduction and Support Package module <i>Guidance on the Documentation Requirements of ISO 9001:2000</i> (document ISO/TC176/SC2/N525 – available from www.bsi.org.uk/iso-tc176-sc2)</p>
--	--	---

5.2 Planning of the process

Steps in the process approach	What to do?	Guidance
5.2.1 Define the activities within the process	Determine the activities needed to achieve the intended outputs of the process.	Define the required inputs and outputs of the process. Determine the activities required to transform the inputs into the required outputs. Determine and define the sequence and interaction of the activities within the process. Determine how each activity will be performed. Note: In some cases, the customer may specify the way the process is to be performed.



**ISO 9000 Introduction and Support Package:
Guidance on the Concept and Use of the Process Approach for management systems**

<p style="text-align: center;">5.2.2 Define the monitoring and measurement requirements</p>	<p>Determine where and how measuring and monitoring should be applied. This should be both for control and improvement of the processes, as well as for the intended process outputs.</p> <p>Determine the need for recording results.</p>	<p>Identify the measures and monitoring criteria for process control and process performance, to determine the effectiveness and efficiency of the process, taking into account factors such as:</p> <ul style="list-style-type: none">• Conformity with requirements,• Customer satisfaction,• Supplier performance,• On time delivery,• Lead times,• Failure rates,• Waste,• Process costs,• Incident frequency.
---	--	--



**ISO 9000 Introduction and Support Package:
Guidance on the Concept and Use of the Process Approach for management systems**



5.2.3 Define the resources needed	Determine the resources needed for the effective operation of each process.	Examples of resources include: <ul style="list-style-type: none"> • Human resources, • Infrastructure, • Work environment, • Information, • Natural resources, • Materials, • Financial resources.
--	---	---



5.2.4 Verify the process against its planned objectives	Confirm that the characteristics of the process are consistent with the purpose of the organization (see 5.1.1)	Verify that all the requirements identified in 5.1.1 are satisfied. If not, consider what additional process activities are required and return to 5.2.1 to improve the process.
--	---	--

**ISO 9000 Introduction and Support Package:
Guidance on the Concept and Use of the Process Approach for management
systems**

5.3 Implementation and measurement of the process

Implement the processes and their activities as planned.

The organization may develop a project for implementation that includes, but is not limited to

- Communication,
- Awareness,
- Training,
- Change management,
- Management involvement,
- Applicable review activities.

Perform the measurements, monitoring and controls as planned.

5.4 Analysis of the process

Evaluate process data obtained from monitoring and measuring, in order to quantify process performance. Where appropriate, use statistical methods.

Compare the results of process performance measurements with the defined requirements of the process to confirm process effectiveness, efficiency and any need for corrective action.

Identify process improvement opportunities based on process performance data.

Report to top management on the performance of the process, as appropriate.

5.5. Corrective action and improvement of the process

The method for implementing corrective actions should be defined, to eliminate the root causes of problems (examples of problems include errors, defects, lack of adequate process controls). Implement the corrective action and verify its effectiveness.

Once the planned process requirements are achieved, the organization should focus its efforts on actions to improve process performance to higher levels, on a continual basis.

The method for improvement should be defined and implemented (examples of improvements include: process simplification, enhancement of efficiency, improvement of effectiveness, reduction of process cycle time). Verify the effectiveness of the improvement.

Risk analysis tools may be employed to identify potential problems. The root cause(s) of these potential problems should also be identified and corrected, preventing occurrence in all processes with similarly identified risks.

The PDCA methodology (Plan-Do-Check-Act) could be a useful tool to define, implement and control corrective actions, and improvements. Extensive literature exists about the PDCA cycle in numerous languages.

ISO 9000 Introduction and Support Package: Guidance on the Concept and Use of the Process Approach for management systems



- “Plan”* *Establish the objectives and processes necessary to deliver results in accordance with customer requirements and the organization's policies;*
- “Do”* *Implement the processes;*
- “Check”* *Monitor and measure processes and product against policies, objectives and requirements for the product and report the results;*
- “Act”* *Take actions to continually improve process performance;”*

The PDCA is a dynamic methodology that can be deployed within each of the organization's processes and their interactions. It is intimately associated with planning, implementation, verification and improvement.

Maintaining and improving process performance can be achieved by applying the PDCA concept at all levels within an organization. This applies equally to high-level strategic processes and to simple operational activities.